

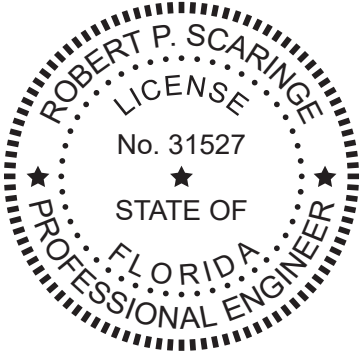

200 YELLOW PLACE  
ROCKLEDGE, FLORIDA 32955

ROBERT P. SCARINGE, P.E.  
FL #31527

OCTOBER 1, 2018



QT8200, QT8210, QT8215, QT8220, QT8230, QT8240

# QwikPad® for Generators

HIGH-VELOCITY HURRICANE ZONE GENERATOR MOUNTING PAD

FLORIDA PRODUCT APPROVAL #FL27646

WIND ANALYSIS OF HURRICANE PADS MAX. WIND SPEED = 180MPH

CODES: FLORIDA BUILDING CODE 2017

RISK CATEGORY II  
ASCE 7-10

## QT8200 GENERATOR PAD

WEIGHT: 330 LB  
WIDTH: 38 IN  
LENGTH: 56 IN  
HEIGHT: 5 IN

$$q_z = 0.00256 \cdot K_z \cdot K_{zt} \cdot K_d \cdot K_e \cdot V^2 \quad (\text{Eq. 26.10-1})$$

$$F = q_z \cdot G \cdot C_f \cdot A_r \quad (\text{Eq. 29.4-1})$$

$K_z = 0.85$  (Table 26.10-1)  
 $K_{zt} = 1.0$  (Sec. 26.8.2)  
 $K_d = 0.85$  (Table 26.6-1)  
 $K_e = 1.00$  (Table 26.9-1)  
 $G = 0.85$  (Sec. 26.11.1)  
 $C_f = 1.3$  (Fig. 29.4-1)

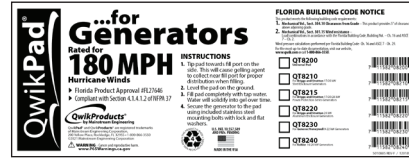

### NOTES:

- LOAD COMBINATION ASD PER 2.4.1 ASCE 7-10 (0.6 X DEAD + 0.6 X WIND)
- DESIGN CONSIDERS ASCE 7-10 SECTION 29.5 DESIGN WIND LOADS - OTHER STRUCTURES. ALL OTHER DESIGN VARIABLES AND LOADING FACTORS ARE IN ACCORDANCE WITH ASCE 7-10 CHAPTERS 26 & 29 FOR EXPOSURE CATEGORY C.
- TOTAL WIND FORCE BASED ON AREA OF UNIT AND PAD ( $F_{WIND, TOT} = F_{WIND, UNIT} + F_{WIND, PAD}$ ).  
TOTAL WIND MOMENT =  $F_{WIND, UNIT} \times (H_{UNIT}/2 + H_{PAD}) + F_{WIND, PAD} \times H_{PAD}/2$ .
- CENTER OF GRAVITY ASSUMED TO ACT AT GEOMETRIC CENTER OF UNIT.
- PAD INSTALLED ON LEVEL GROUND PROVIDES 5" CLEARANCE ABOVE ADJOINING GRADE. DESIGN CONSIDERS 4" CLEARANCE ABOVE GRADE.
- ORIGINAL EQUIPMENT INSTRUCTIONS SUPERSEDE THESE INSTRUCTIONS IF MORE STRINGENT.
- IF UNIT IS TO BE INSTALLED ON EXISTING CONCRETE SLAB, REFER TO TABLE 2 FOR RATED WIND ZONES.
- UNIT MUST BE SECURED TO PAD WITH HARDWARE PROVIDED. INCLUDED HARDWARE BASED ON PAD AND EQUIPMENT MODEL.
- MODEL NUMBER LIST IN GENERATOR PAD SCHEDULE MAY NOT BE ALL INCLUSIVE. MODEL NUMBER VARIANTS MAY EXIST, OR MAY BE ADDED TO PRODUCT LINES, WHICH MEET WIND LOAD RATINGS. GENERATOR MODELS OTHER THAN THOSE LISTED HAVING EQUIVALENT, OR SMALLER, EXTERIOR DIMENSIONS ( $L_G$ ,  $W_G$ ,  $H_G$ ), MATCHING ANCHORAGE PATTERNS, AND WEIGHT GREATER THAN OR EQUAL TO THOSE LISTED SHALL BE CONSIDERED TO MEET GIVEN  $V_{WIND}$  WIND SPEEDS. OTHERWISE, UNITS MUST BE CONSIDERED ON A CASE-BY-CASE BASIS.

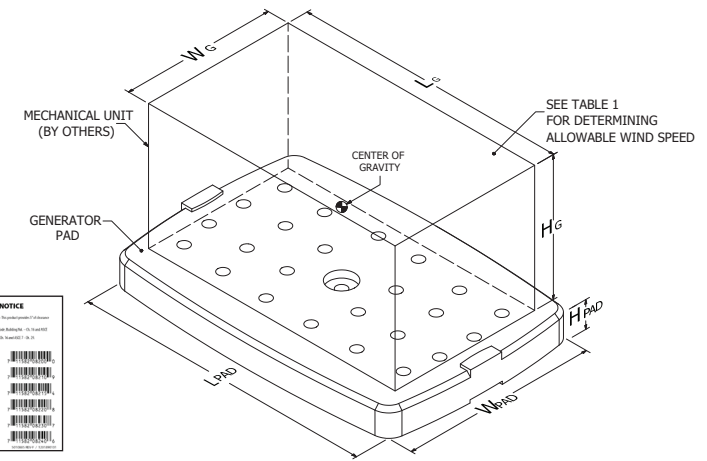

### GENERATOR PAD SCHEDULE:

QWIKPAD® for Generators							GENERATOR						
PART NUMBER	INSTALLED PAD WEIGHT	L <sub>PAD</sub>	W <sub>PAD</sub>	H <sub>PAD</sub>	RATED WIND SPEED	ULTIMATE PRESSURE	MAKE	NOMINAL RATING	SEE DESIGN NOTE 9 MODEL NUMBER	L <sub>G</sub>	W <sub>G</sub>	H <sub>G</sub>	MINIMUM WEIGHT
	LB	IN	IN	IN	MPH	PSF				IN	IN	IN	LB
QT8200	330	56	38	5	180	66.2	UNIVERSAL	-	ALL LISTED MAKES/MODELS	SEE DESIGN NOTE 6			
QT8210	330	56	38	5	180	66.2	BRIGGS & STRATTON	17 kW 20 kW	040459 040336, 040547	47	31	31	484 500
QT8215	330	56	38	5	180	66.2	BRIGGS & STRATTON	17 kW 20 kW 26 kW	0404661 040662, 040657 040658, 040664	46.5	26.8	28.4	520 520 540
QT8220	330	56	38	5	180	66.2	BRIGGS & STRATTON	20 kW	040573, 040574, 040592	49.2	31.7	30.6	443
QT8230	330	56	38	5	180	66.2	GENERAC	9 kW 11 kW 16 kW 20 kW 20 kW	G007029, G007030 G007031, G007032, G007033 G007035, G007036, G007037 G007038, G007039 G007042, G007043	48	25.1	28.6	340 348 409 448 466
QT8230	330	56	38	5	180	66.2	HONEYWELL	16 kW 20 kW 22 kW	G007059 G007062 G007065	48	25.1	28.6	409 448 466
QT8240	330	56	38	5	180	66.2	KOHLER	14 kW 14 kW 20 kW 20 kW	14RESA 14RESAL 20RESA, 20RES 20RESAL, 20 RESCL	48	26.2	29	420 467 535 580

**WIND LOAD CALCULATIONS FOR QT82XX SERIES GENERATOR PADS:  
APPROPRIATE PAD MODEL DETERMINED USING PAD SCHEDULE ON SHEET 1**

**TABLE 1: WIND LOAD OVERTURN DESIGN CHECK FOR  $V_{ULT} = 180$  MPH (EXPOSURE 'C') FOR QT82XX SERIES GENERATOR PADS FOR USE WITH RISK CATEGORY II STRUCTURE IN THE HVHZ.**

MAKE	NOMINAL RATING	MODEL NUMBER	DIMENSIONS			WEIGHT	$V_{ULT} = 180$ MPH WIND SPEED (66.2 PSF ULTIMATE WIND PRESSURE)							
			$L_G$	$W_G$	$H_G$		.6 X DEAD LOAD (UNIT + PAD)	DEAD LOAD MOMENT	$F_{WIND, PAD}$	$F_{WIND, UNIT}$	$F_{WIND, TOT}$	.6 X WIND MOMENT	SF OVERTURN	DESIGN CHECK
-	-	-	IN	IN	IN	LB	LB	FT-LB	LB	LB	LB	FT-LB	-	LB
BRIGGS & STRATTON	17 kW	040459	47	31	31	484	488.4	773.3	128.8	670.0	798.8	702.9	1.100	OK FOR 180 MPH
	20 kW	040336, 040547	47	31	31	500	498.0	788.5	128.8	670.0	798.8	702.9	1.122	OK FOR 180 MPH
	20 kW	040573, 040574, 040592	49.2	31.7	30.6	443	463.8	734.4	128.8	692.3	821.1	718.8	1.022	OK FOR 180 MPH
GENERAC	9 kW	G007029, G007030	48	25.1	28.6	340	402.0	636.5	128.8	631.3	760.1	625.3	1.018	OK FOR 180 MPH
	11 kW	G007031, G007032, G007033	48	25.1	28.6	348	406.8	644.1	128.8	631.3	760.1	625.3	1.030	OK FOR 180 MPH
	16 kW	G007035, G007036, G007037	48	25.1	28.6	409	443.4	702.1	128.8	631.3	760.1	625.3	1.123	OK FOR 180 MPH
	20 kW	G007038, G007039	48	25.1	28.6	448	466.8	739.1	128.8	631.3	760.1	625.3	1.182	OK FOR 180 MPH
	22 kW	G007042, G007043	48	25.1	28.6	466	477.6	756.2	128.8	631.3	760.1	625.3	1.209	OK FOR 180 MPH
HONEYWELL	16 kW	G007059	48	25.1	28.6	409	443.4	702.1	128.8	631.3	760.1	625.3	1.123	OK FOR 180 MPH
	20 kW	G007062	48	25.1	28.6	448	466.8	739.1	128.8	631.3	760.1	625.3	1.182	OK FOR 180 MPH
	22 kW	G007065	48	25.1	28.6	466	477.6	756.2	128.8	631.3	760.1	625.3	1.209	OK FOR 180 MPH
KOHLER	14 kW	14RESA	48	26.2	29	420	450.0	712.5	128.8	640.1	768.9	640.2	1.113	OK FOR 180 MPH
	14 kW	14RESAL	48	26.2	29	467	478.2	757.2	128.8	640.1	768.9	640.2	1.183	OK FOR 180 MPH
	20 kW	20RESA, 20RESC	48	26.2	29	535	519.0	821.8	128.8	640.1	768.9	640.2	1.284	OK FOR 180 MPH
	20 kW	20RESAL, 20 RESCL	48	26.2	29	580	546.0	864.5	128.8	640.1	768.9	640.2	1.350	OK FOR 180 MPH

**TABLE 2. WIND LOAD SLIDING DESIGN CHECK FOR QT82XX SERIES GENERATOR PADS INSTALLED ATOP EXISTING CONCRETE SLAB FOR USE WITH RISK CATEGORY II STRUCTURE (EXPOSURE 'C') IN THE HVHZ.**

MAKE	NOMINAL RATING	MODEL NUMBER	DIMENSIONS				WEIGHT	$V_{ULT} = 180$ MPH WIND SPEED (66.2 PSF ULTIMATE WIND PRESSURE)							DESIGN CHECK (NO ANCHORS)	DESIGN CHECK (1 ANCHOR) †
			$L_G$	$W_G$	$H_G$	NORMAL FORCE		STATIC FRICTION ( $\mu_s = 0.6$ )	$F_{WIND, PAD}$	$F_{WIND, UNIT}$	$F_{WIND, TOT}$	ULTIMATE PRESSURE	WIND SPEED			
-	-	-	IN	IN	IN	LB	LB	LB	LB	LB	LB	PSF	MPH	LB	LB	
BRIGGS & STRATTON	17 kW	040459	47	31	31	484	814.0	488.4	78.7	409.7	488.4	40.49	140.75	UP TO 140 MPH	OK FOR 180 MPH	
	20 kW	040336, 040547	47	31	31	500	830.0	498.0	80.3	417.7	498.0	41.28	142.13	UP TO 142 MPH	OK FOR 180 MPH	
	20 kW	040573, 040574, 040592	49.2	31.7	30.6	443	773.0	463.8	72.7	391.1	463.8	37.40	135.28	UP TO 135 MPH	OK FOR 180 MPH	
GENERAC	9 kW	G007029, G007030	48	25.1	28.6	340	670.0	402.0	68.1	333.9	402.0	35.02	130.91	UP TO 130 MPH	OK FOR 180 MPH	
	11 kW	G007031, G007032, G007033	48	25.1	28.6	348	678.0	406.8	68.9	337.9	406.8	35.44	131.69	UP TO 131 MPH	OK FOR 180 MPH	
	16 kW	G007035, G007036, G007037	48	25.1	28.6	409	739.0	443.4	75.1	368.3	443.4	38.63	137.48	UP TO 137 MPH	OK FOR 180 MPH	
	20 kW	G007038, G007039	48	25.1	28.6	448	778.0	466.8	79.1	387.7	466.8	40.67	141.06	UP TO 141 MPH	OK FOR 180 MPH	
	22 kW	G007042, G007043	48	25.1	28.6	466	796.0	477.6	80.9	396.7	477.6	41.61	142.69	UP TO 142 MPH	OK FOR 180 MPH	
HONEYWELL	16 kW	G007059	48	25.1	28.6	409	739.0	443.4	75.1	368.3	443.4	38.63	137.48	UP TO 137 MPH	OK FOR 180 MPH	
	20 kW	G007062	48	25.1	28.6	448	778.0	466.8	79.1	387.7	466.8	40.67	141.06	UP TO 141 MPH	OK FOR 180 MPH	
	22 kW	G007065	48	25.1	28.6	466	796.0	477.6	80.9	396.7	477.6	41.61	142.69	UP TO 142 MPH	OK FOR 180 MPH	
KOHLER	14 kW	14RESA	48	26.2	29	420	750.0	450.0	75.4	374.6	450.0	38.76	137.70	UP TO 137 MPH	OK FOR 180 MPH	
	14 kW	14RESAL	48	26.2	29	467	797.0	478.2	80.1	398.1	478.2	41.18	141.95	UP TO 141 MPH	OK FOR 180 MPH	
	20 kW	20RESA, 20RESC	48	26.2	29	535	865.0	519.0	86.9	432.1	519.0	44.70	147.89	UP TO 147 MPH	OK FOR 180 MPH	
	20 kW	20RESAL, 20 RESCL	48	26.2	29	580	910.0	546.0	91.4	454.6	546.0	47.02	151.68	UP TO 151 MPH	OK FOR 180 MPH	

† (1) Ø1/4" X 5" ITW CONCRETE SCREW (1.25" MIN. EMBEDMENT IN 3000 PSI MIN. CONCRETE AT 3.0" MIN. EDGE DISTANCE) INSTALLED WITH S.S. FENDER WASHER (13 GA MIN.) FOR  $V_{ULT}$  WIND SPEEDS ABOVE THE 'DESIGN CHECK (NO ANCHORS)' WIND SPEED REQUIRED TO PREVENT SLIDING ON CONCRETE FOR  $V_{ULT}$  WIND SPEEDS UP TO 180 MPH.